

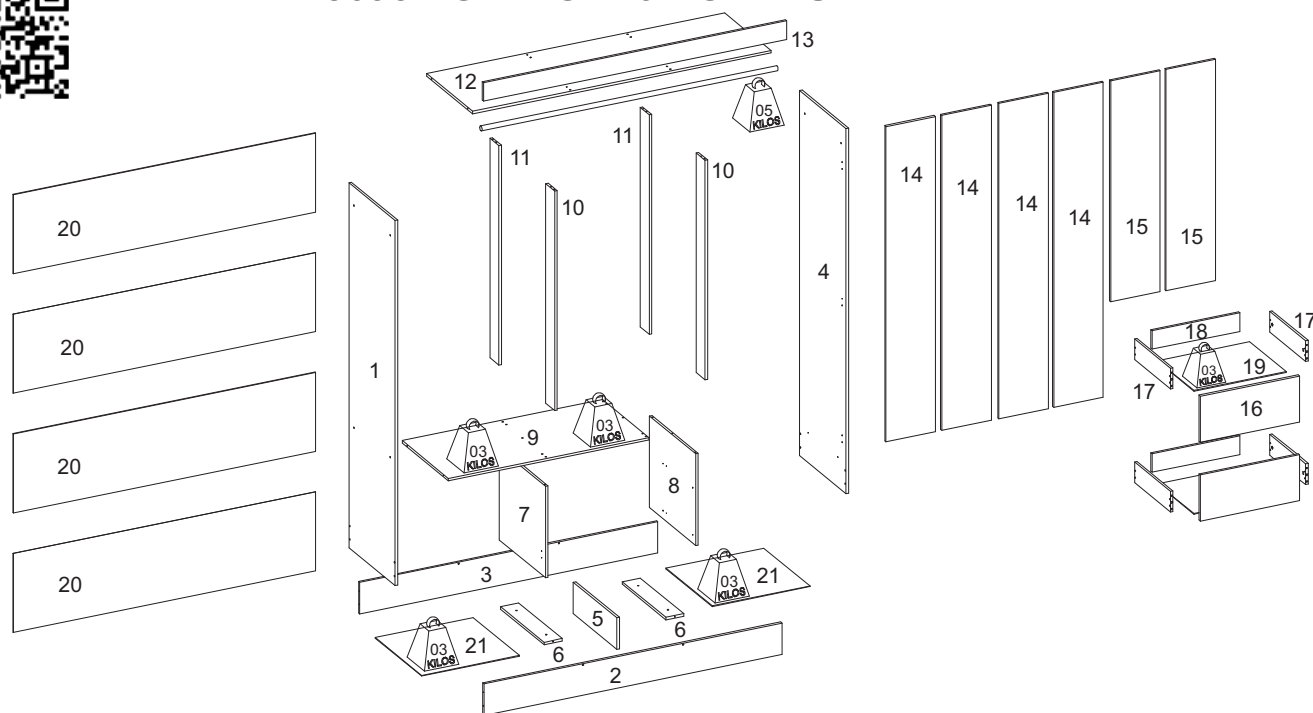

## 8695 - GR MOBI 6 PORTAS



### LISTA DE PEÇAS / PIECES LIST / LISTA DE PIEZAS

| SEQ. | REF.   | DESCRIÇÃO          | DESCRIPTION         | DESCRIPCIÓN              | MAT.PRIMA | COMP. | LARG. | ESP. | QTD. |
|------|--------|--------------------|---------------------|--------------------------|-----------|-------|-------|------|------|
| 1    | 323503 | Lateral esquerda   | Left side           | Lado izquierdo           | MDP       | 1740  | 450   | 12   | 1    |
| 2    | 323504 | Rodapé frontal     | Front skirting      | Zócalo delantero         | MDP       | 1449  | 150   | 12   | 1    |
| 3    | 323505 | Rodapé traseiro    | Rear skirting       | Zócalo trasero           | MDP       | 1449  | 150   | 12   | 1    |
| 4    | 323506 | Lateral direita    | Right side          | Lado derecho             | MDP       | 1740  | 450   | 12   | 1    |
| 5    | 323507 | Trava rodapé       | Plinth latch        | Cierre del zócalo        | MDP       | 424   | 150   | 12   | 1    |
| 6    | 323508 | Trava da divisória | Partition lock      | Bloqueo de la partición  | MDP       | 424   | 88    | 12   | 2    |
| 7    | 323509 | Divisória esquerda | Left-hand partition | Tabique izquierdo        | MDP       | 450   | 436   | 12   | 1    |
| 8    | 323510 | Divisória direita  | Right divider       | Separador derecho        | MDP       | 450   | 436   | 12   | 1    |
| 9    | 323511 | Tampo gaveteiro    | Drawer top          | Parte superior del cajón | MDP       | 975   | 450   | 12   | 1    |
| 10   | 323512 | Batente frontal    | Front stop          | Parada frontal           | MDP       | 1046  | 88    | 12   | 2    |
| 11   | 323513 | Batente traseiro   | Back stop           | Parada trasera           | MDP       | 1046  | 88    | 12   | 2    |
| 12   | 323514 | Chapéu             | Hat                 | Sombrero                 | MDP       | 1449  | 450   | 12   | 1    |
| 13   | 323515 | Vista              | View                | Ver                      | MDP       | 1473  | 88    | 12   | 1    |
| 14   | 323516 | Porta maior        | Bigger door         | Puerta más grande        | MDP       | 1502  | 240   | 12   | 4    |
| 15   | 323517 | Porta menor        | Smaller door        | Puerta más pequeña       | MDP       | 1054  | 240   | 12   | 2    |
| 16   | 323518 | Frente de gaveta   | Drawer front        | Frente del cajón         | MDP       | 483   | 220   | 12   | 2    |
| 17   | 700765 | Lateral de gaveta  | Drawer lateral      | Cajón lateral            | MDP       | 350   | 100   | 12   | 4    |
| 18   | 323520 | Contra fundo       | Back                | Volver                   | MDP       | 426   | 88    | 12   | 2    |
| 19   | 323521 | Fundo da gaveta    | Bottom of drawer    | Fondo del cajón          | HDF       | 448   | 355   | 3    | 2    |
| 20   | 323522 | Fundo              | Bottom              | En el fondo              | HDF       | 1469  | 376   | 3    | 4    |
| 21   | 323523 | Base hdf           | Base hdf            | Base hdf                 | HDF       | 475   | 450   | 3    | 2    |

**INSTRUÇÃO MONTAGEM PRODUTO**  
 Instructions to Assembly / Instrucciones de montaje

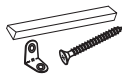

Separe as peças e acessórios de maneira organizada  
 Separate parts and accessories in way organized  
 Separe las piezas y accesorios de manera organizada

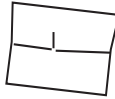

Forrar o chão com o papelão das embalagens.  
 Cover the floor with the cardboard  
 Cubra el suelo con la embalaje de cartón



É necessário 01 pessoas para montar o produto  
 01 people are required to assemble the product  
 Se requieren 01 personas para ensamblar el producto

O produto deve ser a montado por um profissional qualificado  
 The product must be assembly by a professional  
 El producto debe ser ensamblado por un profesional calificado

Ferramentas necessárias  
 (não fornecidas)

Not include tools / No herramientas



**CUIDADO PARA CONSERVAÇÃO E LIMPEZA DO MÓVEL**  
 Care to conservation and clean / Cuidados de limpieza

Peso máximo de carga informado refere-se a objetos distribuido de maneira uniforme sobre toda área de contato da peça



The maximum load weight informed refers to objects distributed evenly over the entire contact area of the part  
 Conjunto de carga máxima de peso se refiere a objetos distribuidos uniformemente sobre toda el área de contacto de la pieza de trabajo.



Não molhar o móvel e não expor em lugar úmido  
 Do not wet the mobile and do not expose in a wet place  
 No moje el producto y no exponer en un lugar húmedo



Não expor o móvel próximo de fontes de calor.  
 Do not expose the mobile near heat sources  
 no exponga cercano de fuentes de calor



Não usar produtos abrasivos.  
 Do not use abrasive products.  
 No utilice productos abrasivos.



Limpe com flanela limpa e seca.  
 Clean with dry cloth  
 Limpieza con un paño limpio y seco

**LISTA DE ACESSÓRIOS E FERRAGENS / ACCESSORIES AND HARDWARE / ACCESORIOS Y HARDWARE**



A- 700137 - Parafuso 4,5x45 (32x)  
 screw / tornillo



B- 700124 - Parafuso 3,5x25 (24x)  
 screw / tornillo



C- 700120 - Parafuso 3,0x12 (61x)  
 screw / tornillo

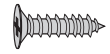

D- 700126  
 Parafuso - 4,0X12 (88X)  
 screw / tornillo



E- 700130 - Parafuso 4,0x16 (4x)  
 screw / tornillo



F- 700542 - Cavilha 6x30 (12x)  
 peg / cerrojo



J- 700146 - Parafuso minifix (4x)  
 Minifix screw / Tornillo minifix



K- 700148  
 Tambor Minifix (4x)  
 Minifix Drum/Tambor minifix



L- 700390 - Calço (16x)  
 700395 - Dobradiça (16x)  
 hinge / bisagra

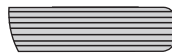

M- 700789 - Bastão madeira (1x)  
 wooden rail / barra maderá



N - 700441 - Suporte prateleira(4x)  
 Support/apoyo

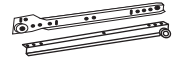

O - 700111  
 Corrediça (02x)  
 runners / corredera



P- 700419 - Tapa furo minifix (4x)  
 minifix cover / tapa minifix



Q - 700516 - SACHE cola 20g (1x)  
 Glue / Goma



R- 701239 - Calço plástico  
 dobradiça (16x )  
 chock / cuña



S- 700437  
 Suporte meia cana (2x)  
 Support / Soporte



T- 700767 - Puxador (8x)  
 Handle / Manija



U- 700157 - Prego (82x)  
 nail / clavo



V- 700538 - Cantoneira (11x)  
 corner / esquina

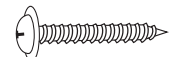

W- 700131  
 Parafuso 4,0x20 (2x)  
 screw / tornillo



Y- 700230 - Pé PVC (6x)  
 PVC foot / Pie de PVC



Z- 700791 - Perfil H (3x)  
 Frame / Perfiló



AA- 700543 - Cavilha 6x60 (4x)  
 peg / cerrojo

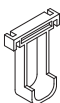

AB - 700434 - Suporte (U) aberto (1X)  
 Open (U) stand / Soporte (U) abierto



AC- 700419 - Tapa furo (14x)  
 minifix cover / tapa minifix

01° PASSO - Fixar peças 5 e 6 nas peças 2 e 3

01° STEP - Fix parts 5 and 6 to parts 2 and 3

01° PASO - Fije las partes 5 y 6 a las partes 2 y 3

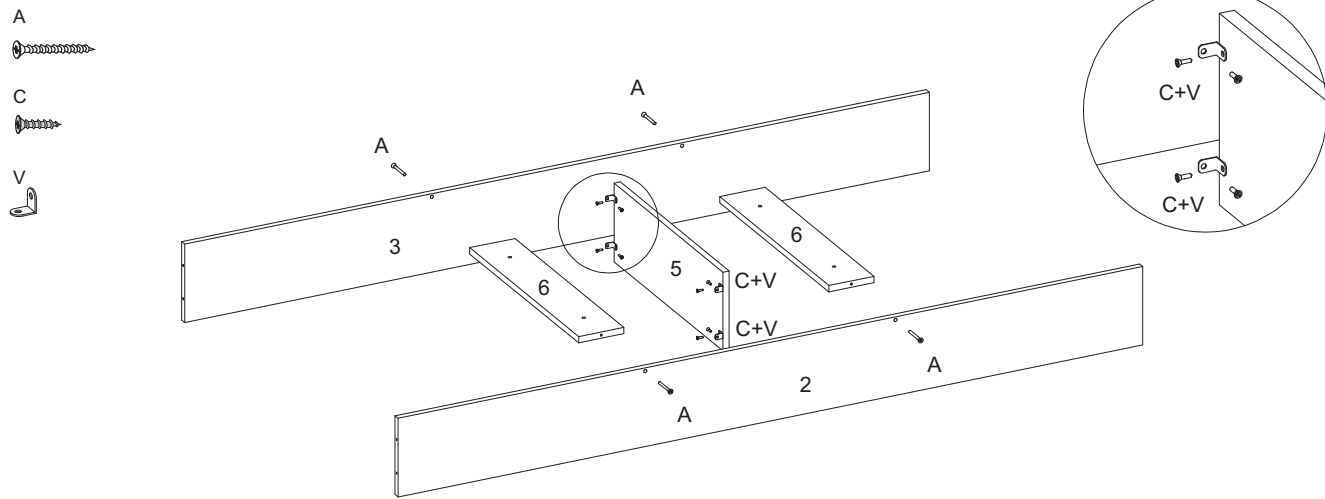

02° PASSO - Fixar peças 1,4,7,8 nas peças 2,3 e 6

02° STEP - Fix parts 1,4,7,8 to parts 2,3 and 6

02° PASO - Fije las partes 1,4,7,8 a las partes 2,3 y 6

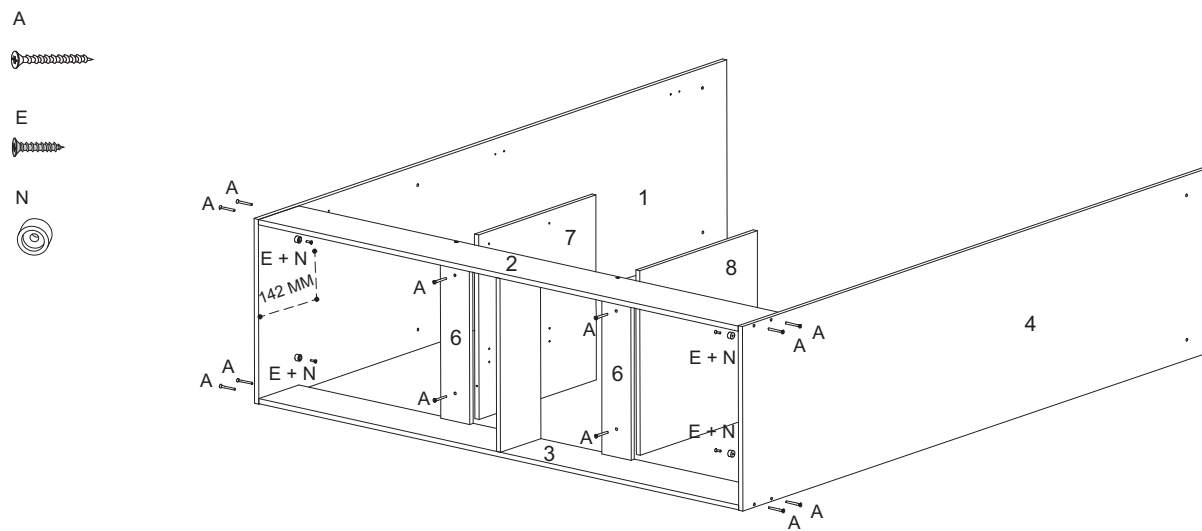

03° PASSO - Fixar os pés nas peças 1,2,3 e 4

03° STEP - Fix the feet to parts 1,2,3 and 4

03° PASO - Fijar los pies a las partes 1,2,3 y 4

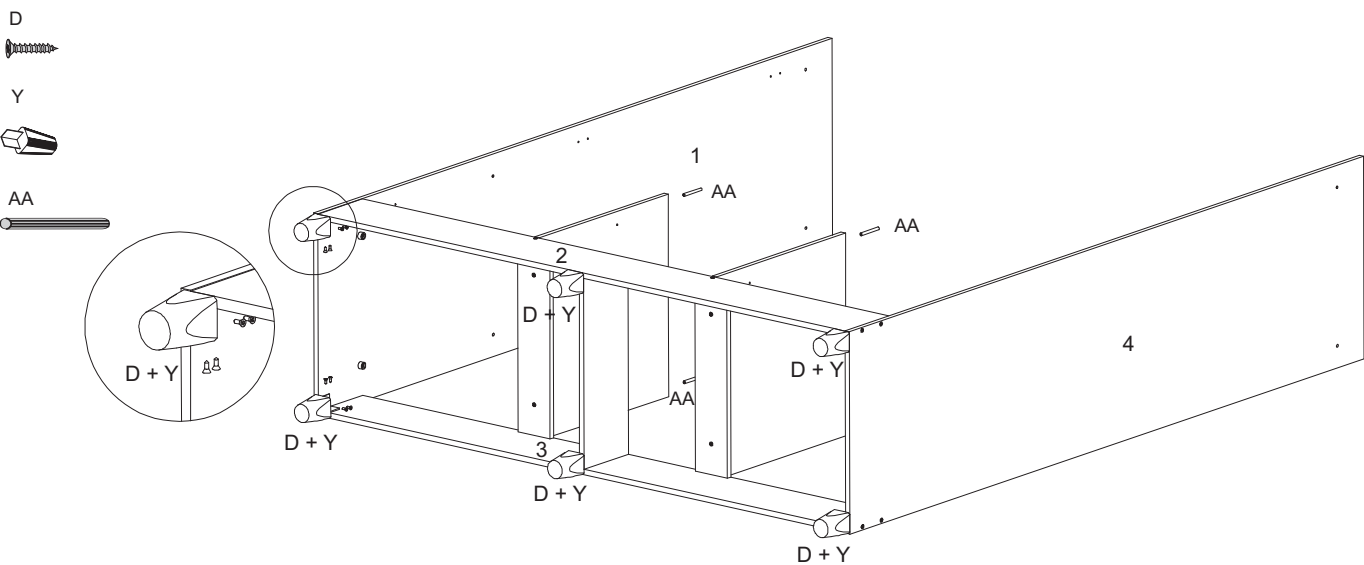

04° PASSO - Fixar peça 10 e 11 na peça 9. Fixar peça 9 nas peças 1,7 e 8

04° STEP - Fix parts 10 and 11 to part 9. Fasten part 9 to parts 1, 7 and 8

04° PASO - Fije las partes 10 y 11 a la parte 9. Fije la parte 9 a las partes 1, 7 y 8

A

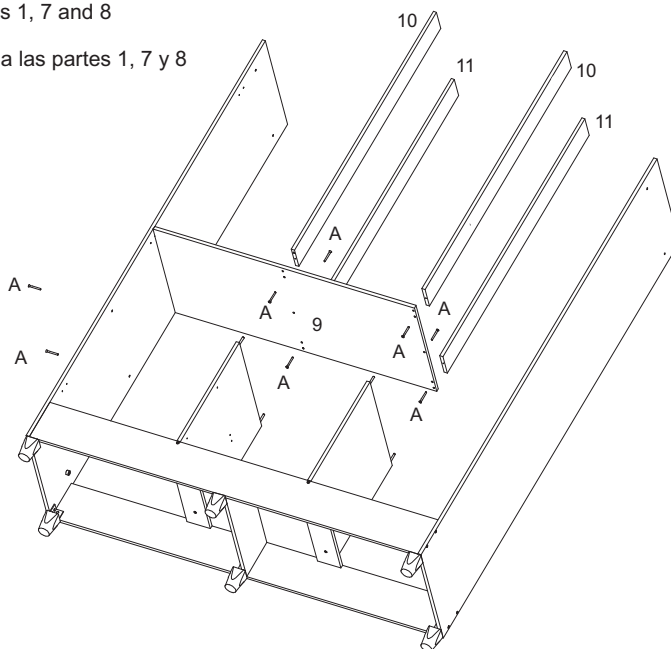

05° PASSO - Fixar peça 12 nas peças 1,4,10 e 11

05° STEP - Fix part 12 to parts 1,4,10 and 11

05° PASO - Fije la parte 12 a las partes 1,4,10 y 11

A



G

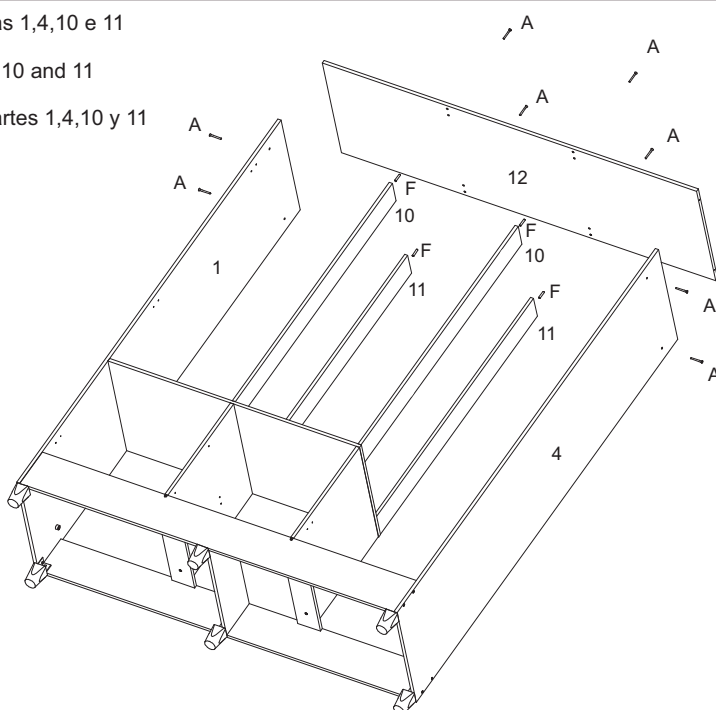

06° PASSO - Fixar peça 13 nas peças 1,4 e 12

06° STEP - Fix part 13 to parts 1, 4 and 12

06° PASO - Fije la parte 13 a las partes 1, 4 y 12

C



V

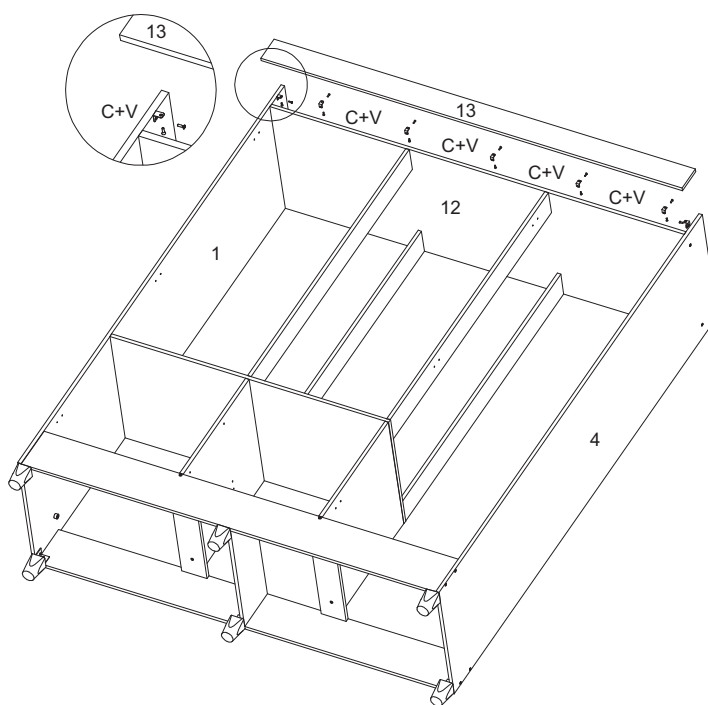

07º PASSO - Fixar peças 20 na parte de trás do produto

07º STEP - Fix parts 20 to the rear of the product

07º PASO - Fije las piezas 20 en la parte trasera del producto

U



Z

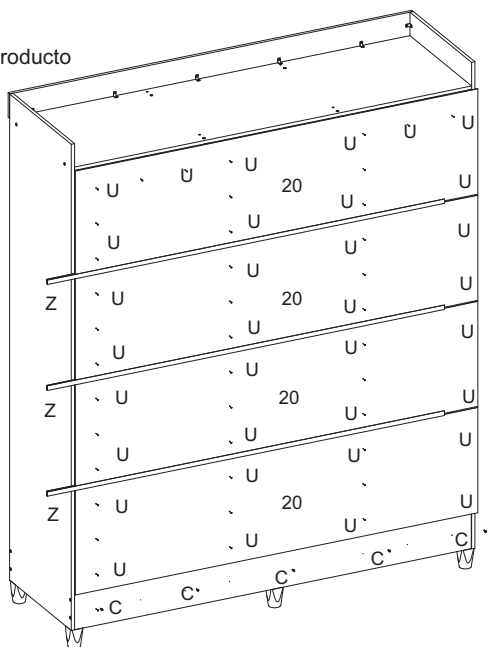

08º PASSO - Fixar o cabideiro e as corredeira no produto

08º STEP - Fix the hangers and runners to the product

08º PASO - Fije los colgadores y las guías al producto

C



M



O



W



AB

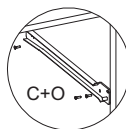
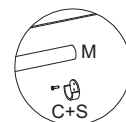
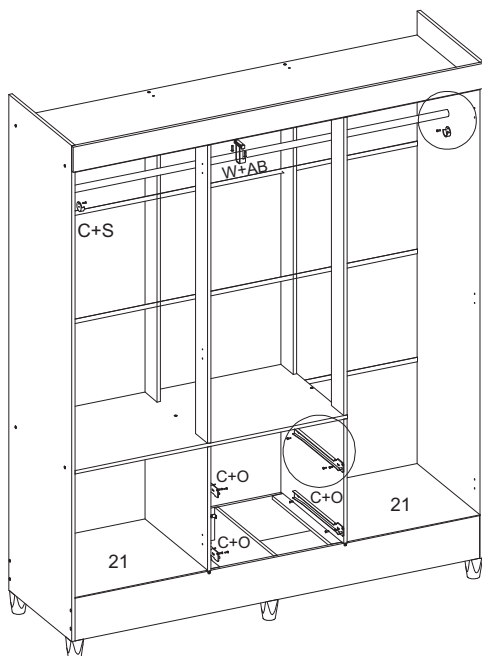

09º PASSO - Fixar peças 17 nas peças 16 e 18

09º STEP - Fix the accessories in the indicated places

09º PASO - Fijar partes 17 con las partes 16 y 18

B



F



J



K



T

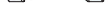

P



Q

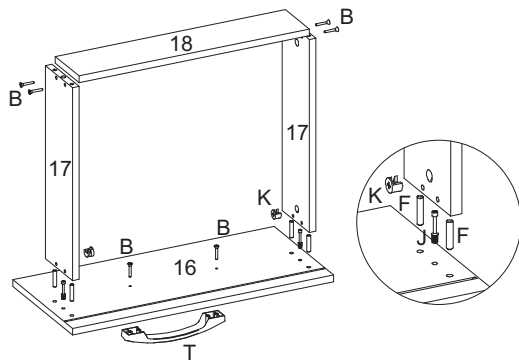

10º PASSO - Fixar a peça 11 utilizando as ferragens C e H

10º STEP - Fix part 11 using hardware C and H.

10º PASO - Arregle la parte 11 usando hardware C y H

C



H

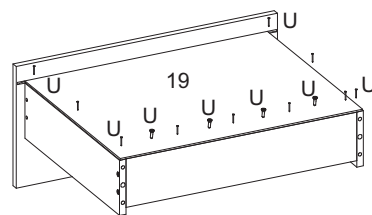

11º PASSO - Fixar acessórios (C+O) nas peças 19 e 17

11º STEP - Fix accessories (C+O) to parts 19 and 17

11º PASO - Fijar los accesorios (C+O) en las piezas 19 y 17

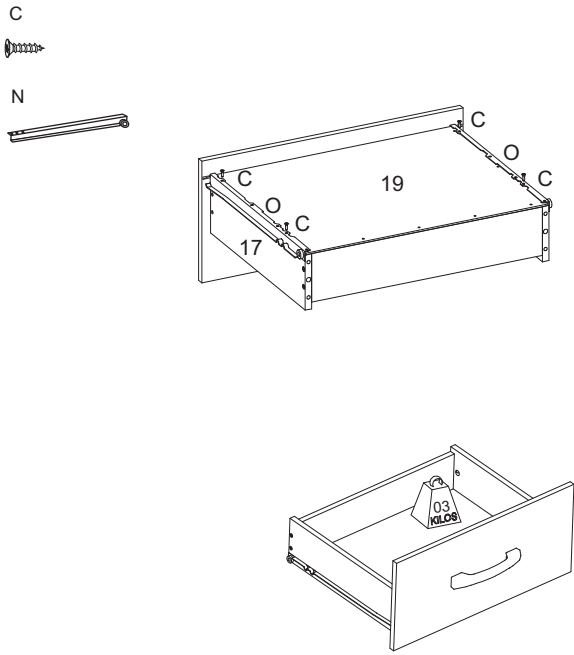

12º PASSO - Fixar peças 14 e 15 utilizando os acessórios (D + L + R)

12º STEP - Fix parts 14 and 15 using the accessories (D + L + R)

12º PASO - Fije las piezas 14 y 15 con los accesorios (D + L + R)

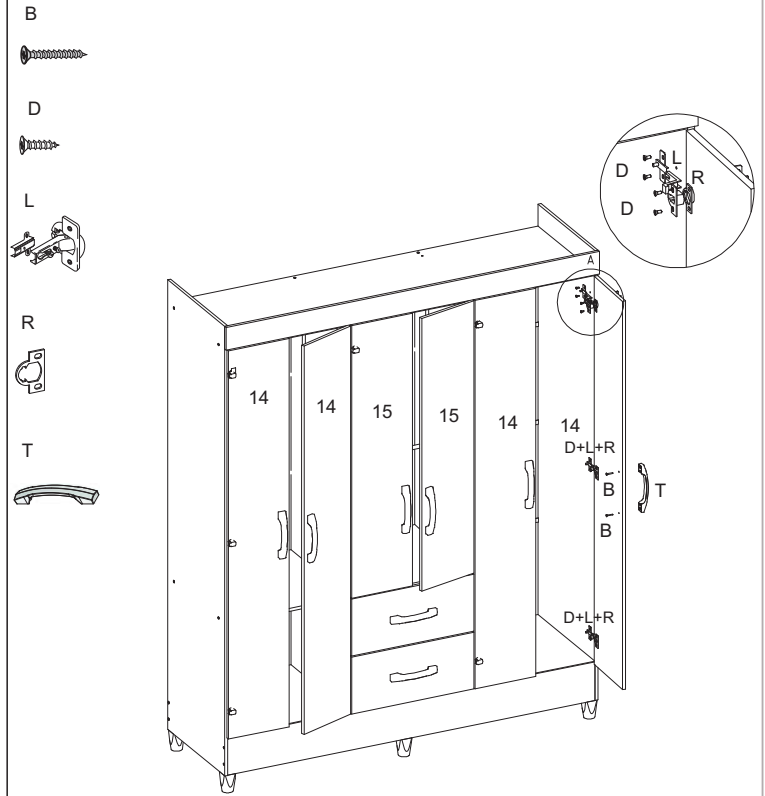

MONTAGEM PARA O PRODUTO QUE CONTEM ESPELHO  
ASSEMBLY FOR THE PRODUCT THAT CONTAINS MIRROR  
MONTAJE DEL PRODUCTO QUE CONTIENE ESPEJO

Atenção / Watch / Atención

Antes de colar o espelho. Favor, limpar a superfície da peça com um pano seco

Before gluing the mirror. Please clean the surface of the piece with a dry cloth

Antes de pegar el espejo Por favor, limpie la superficie de la pieza con un paño seco

Aspecto final do produto

Final appearance of the product

Aspecto final del producto

